

People with paraplegia can find help in new spinal implant

November 22 2010



The active electrode book

Engineers have developed a new type of microchip muscle stimulator implant that will enable people with paraplegia to exercise their paralysed leg muscles.

It is the first time that researchers have developed a device of this kind that is small enough to be implanted into the spinal canal and incorporates the electrodes and muscle stimulator in one unit. The implant is the size of a child's fingernail.

The Engineering and Physical Sciences Research Council (EPSRC) project is being led by Professor Andreas Demosthenous from University College London. It includes engineers from Freiburg University and the Tyndall Institute in Cork.

"The work has the potential to stimulate more muscle groups than is currently possible with existing technology because a number of these devices can be implanted into the spinal canal", said Professor Andreas Demosthenous. "Stimulation of more muscle groups means users can perform enough movement to carry out controlled exercise such as cycling or rowing."

The devices could also be used for a wide range of restorative functions such as stimulating bladder muscles to help overcome incontinence and stimulating nerves to improve bowel capacity and suppress spasms.

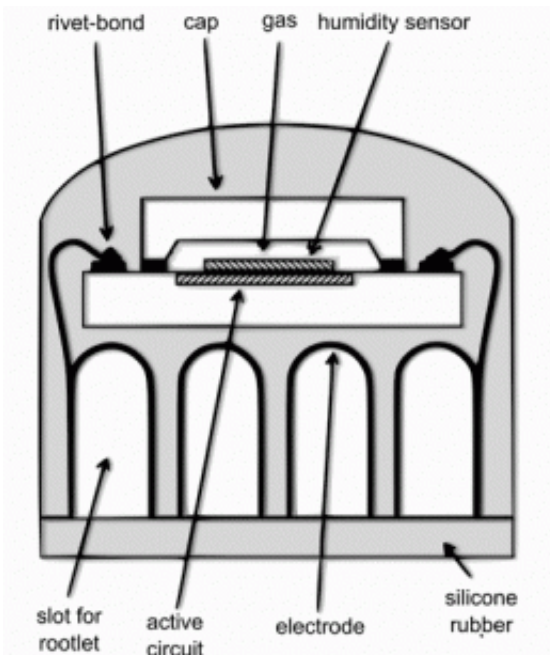

The research team has overcome previous limitations by micro-packaging everything into one tiny unit. Latest laser processing technology has been used to cut tiny electrodes from platinum foil. These are then folded into a 3D shape (which looks like the pages of a book, earning the device the name of the Active Book). The pages close in around the nerve roots. They are micro-welded to a [silicon chip](#) which is hermetically sealed to protect against water penetration, which can lead to corrosion of the electronics.

The exciting innovation has been welcomed by Universities and Science Minister David Willetts, who said:

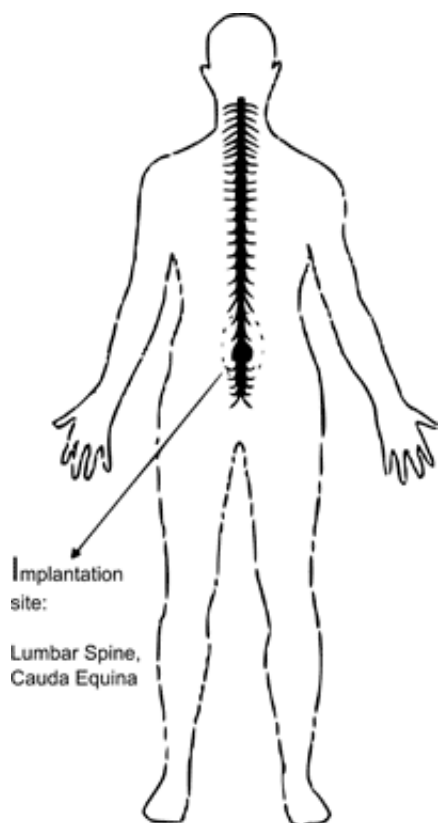

The implant site on the spinal canal

"The Active Book is a good example of how UK scientists and engineers are translating research into innovations that deliver real benefits for society. This tiny implant has the potential to make a real difference to the lives and long-term health of people with paraplegia in the UK and around the world."

The Active Book will be made available for pilot studies sometime next year.

Provided by Engineering and Physical Sciences Research Council

Citation: People with paraplegia can find help in new spinal implant (2010, November 22)
retrieved 26 April 2024 from

<https://medicalxpress.com/news/2010-11-people-paraplegia-spinal-implant.html>

This document is subject to copyright. Apart from any fair dealing for the purpose of private study or research, no part may be reproduced without the written permission. The content is provided for information purposes only.