

# A new genetic marker for schizophrenia

September 5 2017

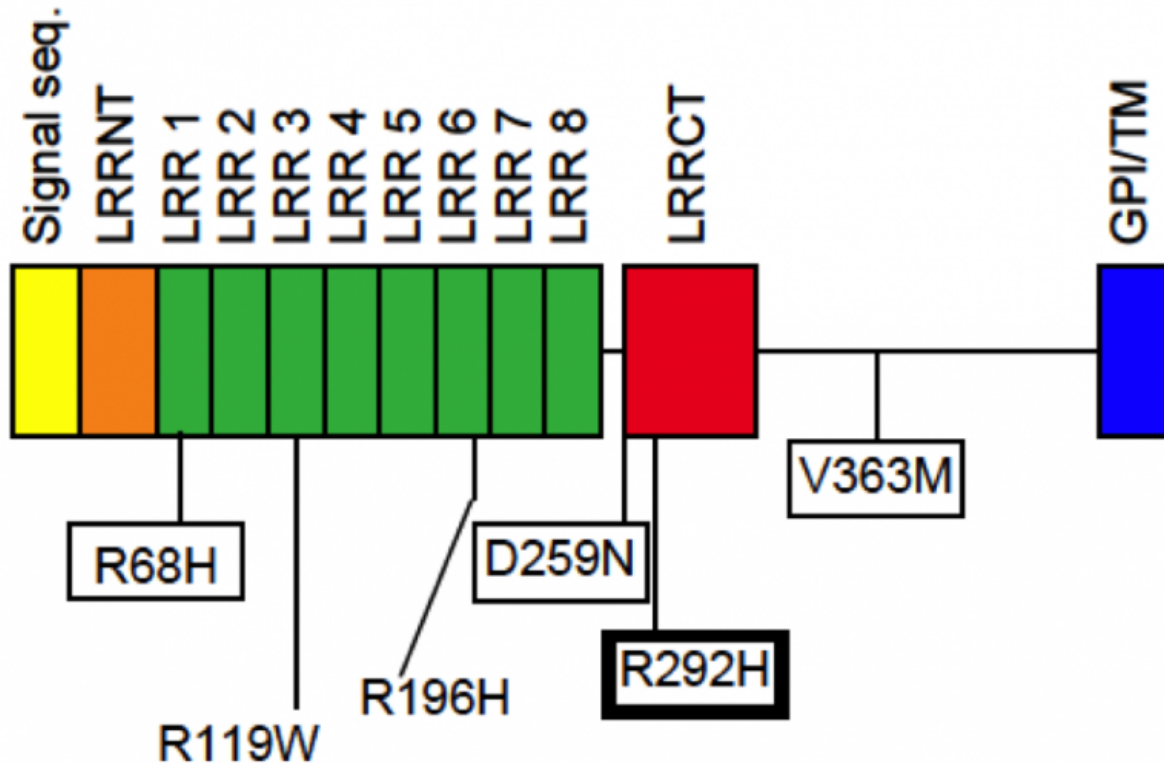

Fig.1. Schematic image of the RTN4R protein. The site of R292H in the signaling domain is indicated. Credit: Osaka university

Schizophrenia is a complicated disease that often appears in early adulthood. Although scientists have not traced the genetic causes, more than 80% of schizophrenia cases are considered to have a hereditary cause. In a new report published in *Translational Psychiatry*, Japanese

researchers report that a rare genetic variant, RTN4R, may have a fundamental role in the disease.

"Schizophrenia is a [disease](#) caused by disturbances in neural circuits. Myelin-related genes are associated with the disease," explains Osaka University Professor Toshihide Yamashita, one of the authors of the studies.

Myelin acts as a conductor of signals for the neural circuits. Yamashita hypothesized that myelin-related genes could contribute to the pathology of [schizophrenia](#).

RTN4R is a subunit of RTN4, which regulates crucial functions for [neural circuits](#), namely, axon regeneration and structural plasticity.

Moreover, "RTN4 is a promising candidate gene for schizophrenia because it is located at chromosome 22q11.2, a hotspot for schizophrenia," he said.

Rare variants describe mutations that have low frequency but a large effect. Yamashita and his colleagues searched for rare variants of RTN4. Screening the DNA of 370 [schizophrenia patients](#), he found a single missense mutation, R292H, that changed the amino acid of this protein from arginine to histidine in two patients.

R292H is located in the domain of RTN4R that binds to ligands, so a change in even a single amino acid could have profound effects on RTN4 function (Figure 1). To test this possibility, the scientists expressed the mutation in chick retinal cells, which only weakly express the gene, finding a significant change in myelin-dependent axonal behavior (Figure 2). Computer simulations showed that the mutation reduced the interaction between RTN4 and its partner protein, LINGO1, by increasing the distance between the two.

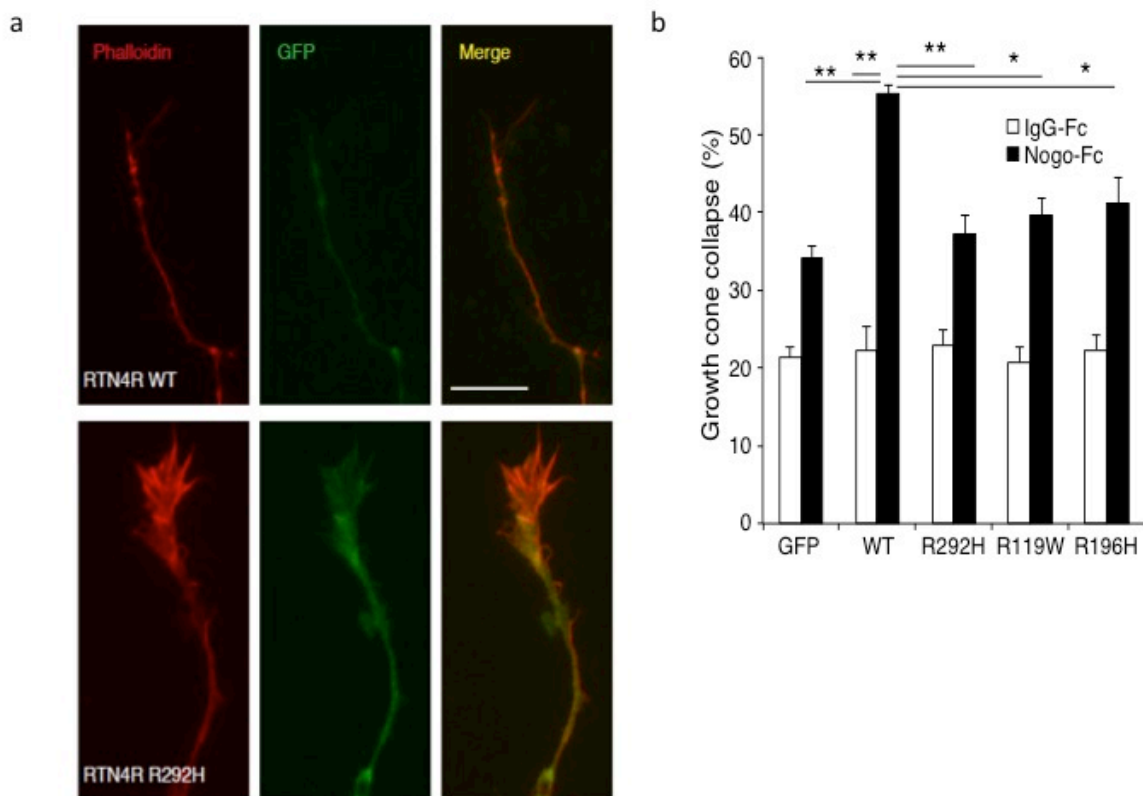

Fig.2. Effect of RTN4R-mutants on growth cone collapse (a) Representative images of growth cone in chick retinal cells cultured in the presence of the RNT4R ligand RTN4. (b) Quantitative analysis of growth cone collapse. Chick dissociated retinal neurons transfected with the indicated plasmids encoding EGFP-RTN4R WT or mutants were cultured in the presence or absence of RTN4. \*\*P

Citation: A new genetic marker for schizophrenia (2017, September 5) retrieved 5 July 2024 from <https://medicalxpress.com/news/2017-09-genetic-marker-schizophrenia.html>

This document is subject to copyright. Apart from any fair dealing for the purpose of private study or research, no part may be reproduced without the written permission. The content is

provided for information purposes only.