

Pop-up electrode device could help with 3D mapping of the brain

January 23 2023, by Sarah Small

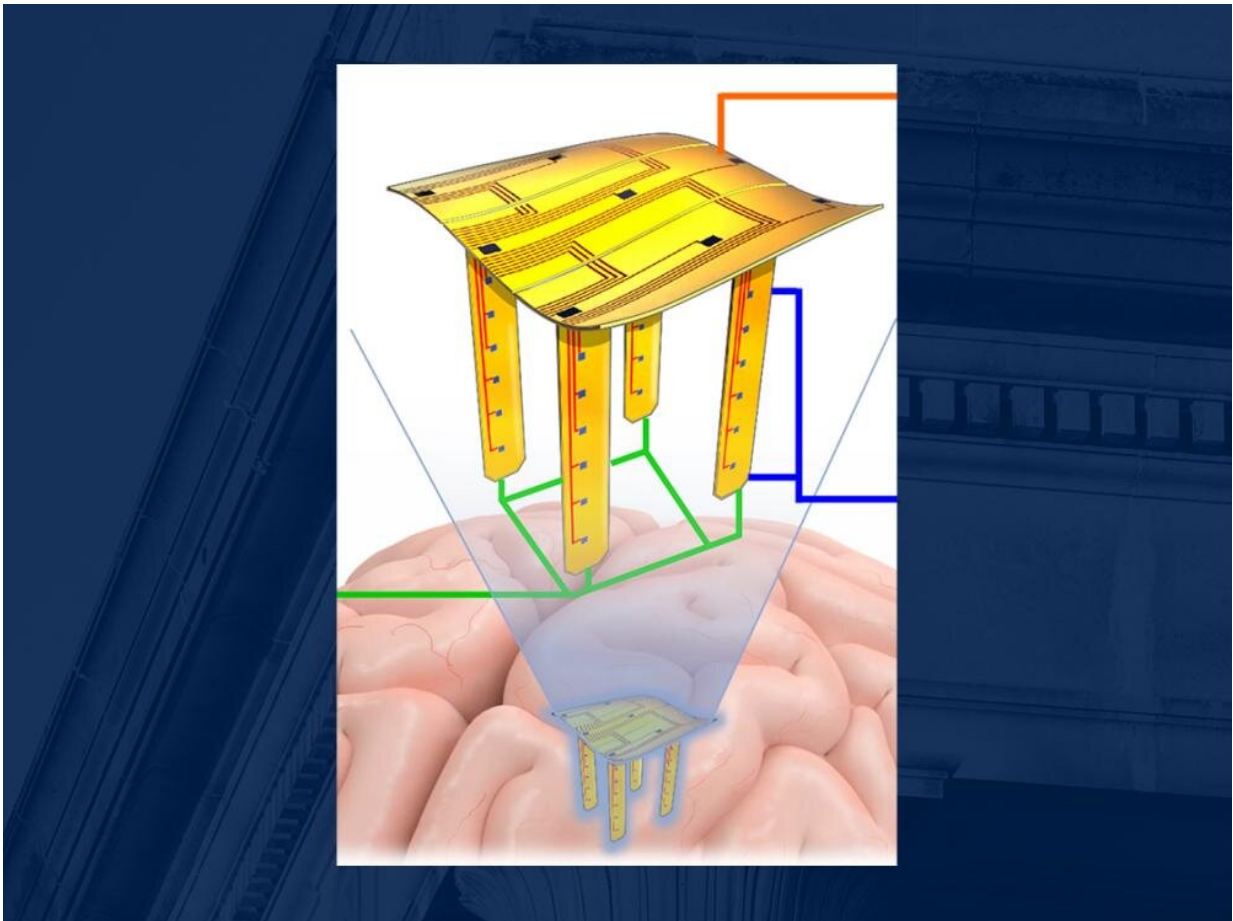

A newly developed sensor electrode device can be popped up into 3D geometry before being inserted into the brain. This design could lead to gathering more in-depth information about individual neurons and their interactions with each other while limiting the potential for brain tissue damage. Credit: Huanyu "Larry" Cheng

Understanding the neural interface within the brain is critical to understanding aging, learning, disease progression and more. Existing methods for studying neurons in animal brains to better understand human brains, however, all carry limitations, from being too invasive to not detecting enough information. A newly developed, pop-up electrode device could gather more in-depth information about individual neurons and their interactions with each other while limiting the potential for brain tissue damage.

The researchers, co-led by Huanyu "Larry" Cheng, James L. Henderson, Jr. Memorial Associate Professor of Engineering Science and Mechanics in the College of Engineering, published their results in *npj Flexible Electronics*.

"It's a challenge to understand the connectivity in between the large number of neuron cells within the brain," Cheng said. "In the past, people developed a device that is placed directly on the cortex to detect information on the [surface layer](#), which is less invasive. But without inserting the device into the brain, it's challenging to detect the intercortical information."

In response to this limitation, researchers developed probe-based electrodes that are inserted into the brain. The problem with this method is that it is not possible to get a 3D layout of the neurons and brain without doing multiple probes, which are difficult to place on a flexible surface and would be too damaging to the [brain tissue](#).

"To address this issue, we use the pop-up design," Cheng said. "We can fabricate the sensor electrodes with resolution and performance comparable with the existing fabrication. But at the same time, we can pop them up into the 3D geometry before they are inserted into the brain. They are similar to the children's pop-up books: You have the flat shape, and then you apply the compressive force. It transforms the 2D

into 3D. It provides a 3D device with the performance comparable with the 2D."

The researchers said that in addition to the unique design that pops up into three dimensions after being inserted into the brain, their device also uses a combination of materials that had not been used in this particular way before. Specifically, they used [polyethylene glycol](#), a material that has been used before, as a biocompatible coating to create stiffness, which is not a purpose for which it has been used previously.

"To insert the device in the brain, it needs to be stiff, but after the device is in the brain, it needs to be flexible," said co-corresponding author Ki Jun Yu of Yonsei University in the Republic of Korea. "So we used a biodegradable coating that provides a stiff outer layer on the device. Once the device is in the brain, that stiff coating dissolves, restoring the initial flexibility. Taking together the material structure and the geometry of this device, we'll be able to get input from the brain to study the 3D neuron connectivity."

Next steps for the research include iterating on the design to make it beneficial not only for gaining a better understanding of the brain but also for surgeries and disease treatments.

"In addition to animal studies, some applications of the device use could be operations or treatments for diseases where you may not need to get the device out, but you'll certainly want to make sure the device is biocompatible over a long period of time," Cheng said. "It is beneficial to design the structure as small, soft and porous as possible so that the [brain](#) tissue can penetrate into and be able to use the device as a scaffold to grow up on top of that, leading to a much better recovery. We also would like to use biodegradable material that can be dissolved after use."

More information: Ju Young Lee et al, Foldable three dimensional

neural electrode arrays for simultaneous brain interfacing of cortical surface and intracortical multilayers, *npj Flexible Electronics* (2022).
[DOI: 10.1038/s41528-022-00219-y](https://doi.org/10.1038/s41528-022-00219-y)

Provided by Pennsylvania State University

Citation: Pop-up electrode device could help with 3D mapping of the brain (2023, January 23)
retrieved 25 April 2024 from
<https://medicalxpress.com/news/2023-01-pop-up-electrode-device-3d-brain.html>

This document is subject to copyright. Apart from any fair dealing for the purpose of private study or research, no part may be reproduced without the written permission. The content is provided for information purposes only.